



# TM-ALEXA2-A

Electronic Bench Scale

Kapasitas 30kg ~ 150kg

Timbangan duduk untuk segala keperluan di industri makanan & minuman, pergudangan, percetakan, dll



- Rangka aluminum, kuat dan tahan lama
- Rangka finishing sand-blasting & powder coating
- Platform Stainless Steel
- Multi fungsi: Checkweigh, Hi/Lo Alarm Limit, dan Hold
- Dilengkapi fitur koneksi Bluetooth-Android Smartphone
- Dapat dicharge menggunakan powerbank
- Green LED double-display cocok untuk penggunaan outdoor
- Tahan terhadap siraman air
- Optional Pagar Pelindung
- Dilengkapi swivel untuk kenyamanan pengguna

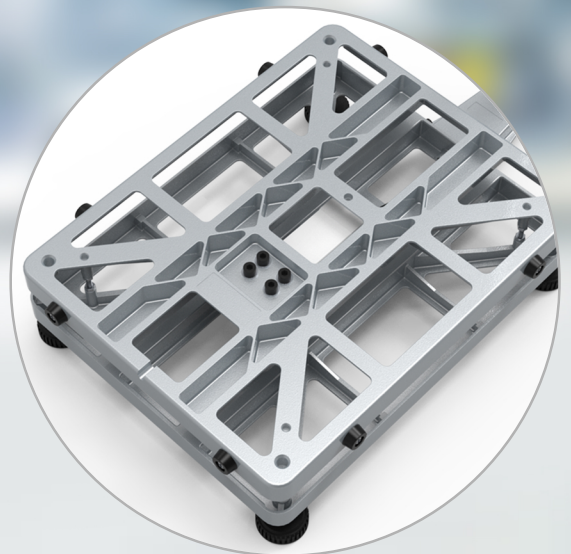

Rangka Aluminum dengan finishing sand-blasting & powder coating

# TM-ALEXA2-A

Electronic Bench Scale

Kapasitas 30kg ~ 150kg

## Fitur

- Finishing Sand-blasting & Powder Coating
- Platform Stainless Steel
- Fungsi BT, Hold, High/OK/Low limit & alarm
- Fungsi Auto-sleep untuk menghemat baterai
- Lampu LED berwarna hijau untuk meningkatkan kenyamanan pakai
- Dapat digunakan dengan atau tanpa Baterai
- Baterai isi ulang
- Dua layar (depan & belakang)

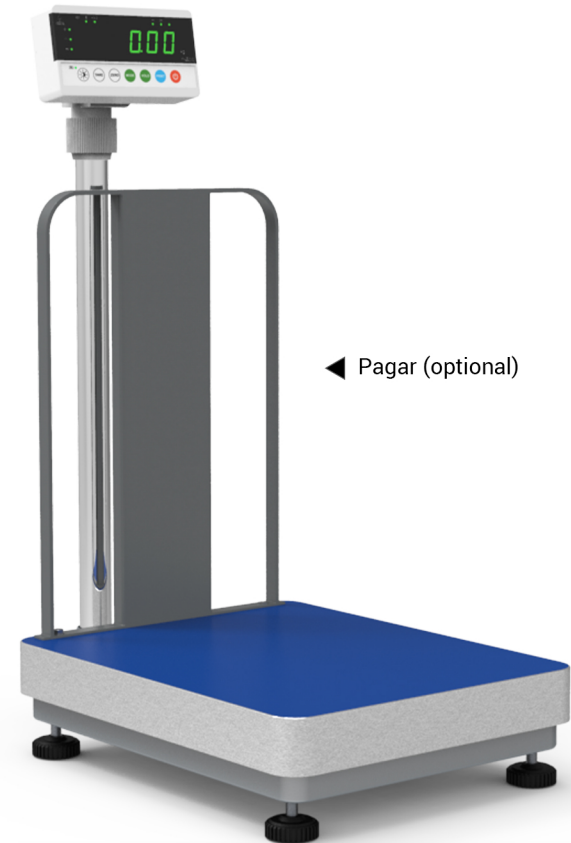
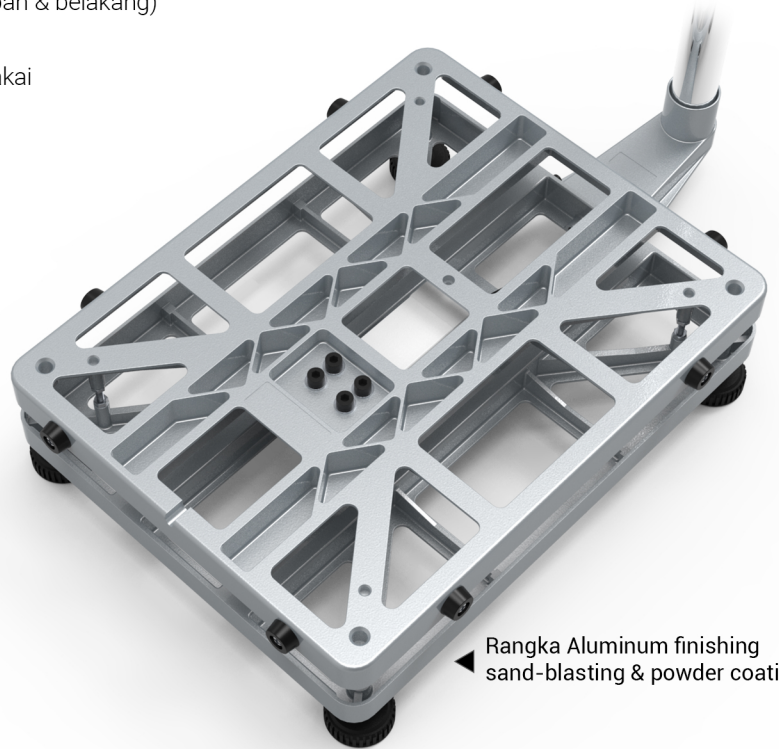

## Dimensi (Unit: mm)

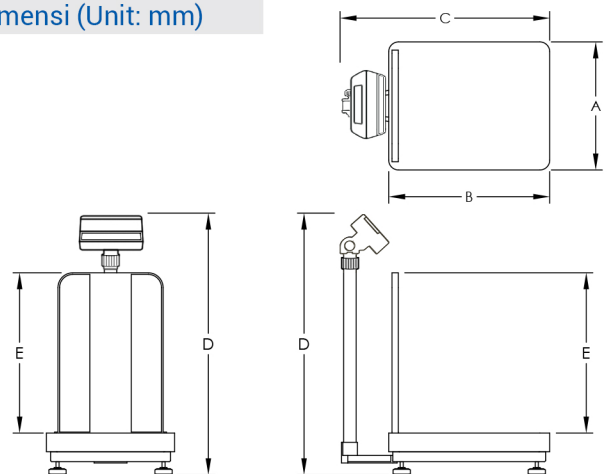

Capacity	A	B	C	D	E
30 ~ 60kg	290	380	530	510	265
150kg	390	490	640	745	490

Model	TM-ALEXA2-30kg	TM-ALEXA2-60kg	TM-ALEXA2-150kg
Capacity	30kg x 5g	60kg x 10g	150kg x 20g
Platform Size	290 x 380 mm		390 x 490 mm
Weight	7 kg		
Display	Depan: 1" Green LED (6 digit)		Belakang: 0.8" Green LED (6 digit)
Designators	BT CONNECTION, HOLD, ZERO, STABLE, TARE, CHARGE, LOW-BATT, HIGH/OK/LOW		
Power Source	5VDC/3.7Ah rechargeable battery or 230 VAC		